

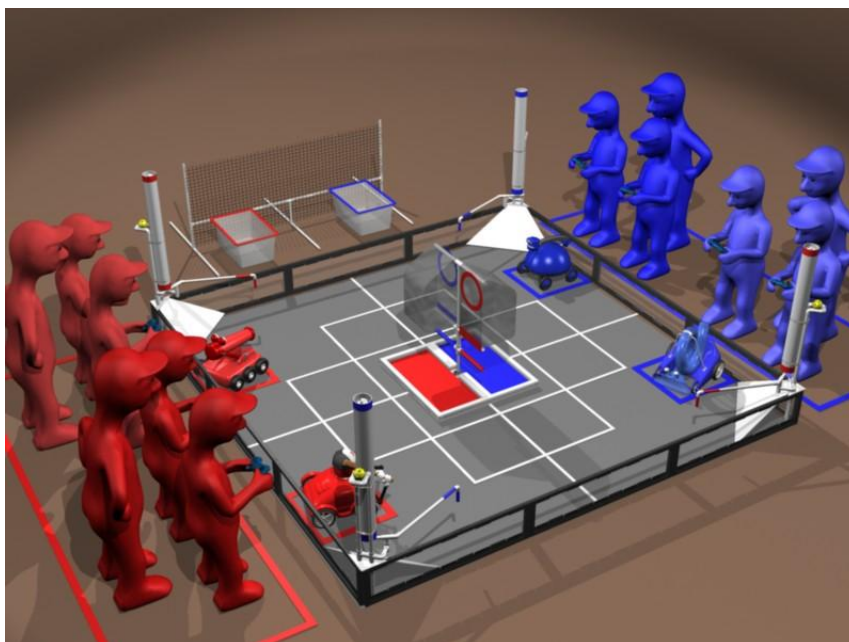

FIRST[®] TECH CHALLENGE



2009/2010 GAME MANUAL

Document Revision History

Revision	Date	Changes
1	09/10/09	Initial Release
2	9/11/09	2.2 changed "one special Bonus Balls" to "Bonus Ball" 2.3. Clarified definition of the bonus ball. 9.4 Added R5C line to Inspection sheet: "Robot contains no more than 24"x24"x 0.080" thick PETG Added revision history page
3	9/15/09	Section 4, <R8>, second paragraph: Change FMS to FCS. Section 6.3, First sentence: Change FMS to FCS.
4	9/30/09	Section 2.3 under "Scoring" Lower goal area definition revised from "extending upward infinitely" to "extending upward to the bottom of the spin bar" Section 2.4.6, Penalty Summary: <SG7> revised: Spinning the bar during autonomous will incur a 40 point penalty.

CONTENTS

Section 1 – Introduction 7

 1.1 – Overview 7

 1.2 – About *FIRST* 7

 1.3 – What is the *FIRST* Tech Challenge? 8

 1.4 – Gracious Professionalism – A *FIRST* Credo 8

 1.5 – The *FIRST* Tech Challenge – 2009 Season..... 8

Section 2 – The Game 10

 2.1 – Overview 10

 2.2 – Game Description..... 10

 2.3 – Game Definitions..... 11

 2.4 – Game Rules 14

 2.4.1 – Scoring 14

 2.4.2 – Scoring in Autonomous Mode 14

 2.4.3 – Safety Rules..... 14

 2.4.4 – General Game Rules 14

 2.4.5 – *Hot Shot!* Specific Game Rules..... 16

 2.4.6 – *Hot Shot!* Penalty Summary..... 17

Section 3 – The Tournament 19

 3.1 – Overview 19

 3.2 – Tournament Definitions 19

 3.3 – Tournament Event Agendas..... 20

 3.4 – Courtesies and Rules 20

 3.5 – Eye Protection and Safety 21

 3.6 – Event Day Overview 21

 3.6.1 – Team Registration..... 21

 3.6.2 – Robot and Software Inspection 21

 3.6.3 – Judge’s Interviews..... 22

2009-10 *FIRST*® TECH CHALLENGE GAME MANUAL

3.6.4 – Practice Matches22

3.6.5 – Opening Ceremony22

3.6.6 – *Qualifying Matches*.....22

3.6.7 – Alliance Selection23

3.6.8 – Elimination Matches24

3.6.9 – Awards and Closing Ceremony25

3.7 – Tournament Rules25

3.8 – Team Spirit26

 3.8.1 – Team Styling.....26

 3.8.2 – Banners and Flags26

 3.8.3 – Spectators and Etiquette26

 3.8.4 – Scouting26

Section 4 - The Robot 28

 4.1 – Overview28

 4.2 – Robot Rules28

 4.3 – Programming Guidelines34

Section 5 – Engineering Notebooks 35

 5.1 – Overview35

 5.2 – What is an Engineering Notebook?35

 5.3 – The Notebook35

 5.4 – Guidelines/Format35

 5.5 – Judge’s Tips37

 5.6 – Virtual Help37

 5.7 – Notebook Examples37

Section 6 – Field Control System 38

 6.1 – Overview38

 6.2 – The Field Control System (FCS)38

 6.3 – Functions performed by the FCS38

 6.3.1 – Robot Pairing and Field Connection38

2009-10 *FIRST*® TECH CHALLENGE GAME MANUAL

6.3.2 – Robot development control.....39

6.3.3 – Team match control.....39

6.4 – How to Use the FCS.....39

Section 7 – Judging & Awards Criteria 40

7.1 – Overview 40

7.2 – *FIRST* Tech Challenge Awards Eligibility 40

7.2.1 - Local Events 40

7.2.2 - Qualifiers 40

7.2.3 - Championship Tournaments 40

7.3 – *FIRST* Tech Challenge Award Categories 41

7.3.1 – *FIRST* Tech Challenge Inspire Award 41

7.3.2 – Rockwell Collins Innovate Award 41

7.3.3 – *FIRST* Tech Challenge PTC Design Award 42

7.3.4 – *FIRST* Tech Challenge Connect Award 42

7.3.5 – *FIRST* Tech Challenge Motivate Award 43

7.3.6 – *FIRST* Tech Challenge Think Award 43

7.3.7 – *FIRST* Tech Challenge Winning Alliance Award 43

7.3.8 – *FIRST* Tech Challenge Finalist Alliance Award 44

7.4 – Judging Process, Schedule, and Team Preparation 44

7.4.1 – Judging Process.....44

7.4.2 – Judging Schedule44

7.4.3 – Team Preparation44

7.5 – *FIRST* Tech Challenge Championship Event Eligibility 45

Section 8 – Team Resources 46

8.1 – Overview 46

8.2 – *FIRST* Contact Information 46

8.3 – Getting Answers to Your Questions 46

8.4 – Technical Support..... 46

2009-10 *FIRST*® TECH CHALLENGE GAME MANUAL

8.5 – Team Development Support47

8.6 – Using the *FIRST*, FTC, and game Logos47

Section 9 – Robot Inspection 48

9.1 – Overview48

9.2 – Description48

9.3 – Definitions48

9.4 – Inspection Rules48

Competition Inspection Checklist 51

SECTION 1 – INTRODUCTION

1.1 – OVERVIEW

This section provides an introduction to *FIRST* and the *FIRST* Tech Challenge program.

1.2 – ABOUT *FIRST*

“...to create a world where science and technology are celebrated... where young people dream of becoming science and technology heroes.”

FIRST Founder, Dean Kamen

FIRST

FIRST (For Inspiration and Recognition of Science and Technology) was founded by inventor Dean Kamen to inspire young people’s interest and participation in science and technology. Based in Manchester, New Hampshire, *FIRST* is a 501(c)(3) not-for-profit public charity.

As a volunteer-driven organization, *FIRST* is built on partnerships with individuals as well as businesses, educational institutions, and government. Some of the world’s most respected companies provide funding, mentorship time and talent, and equipment to make *FIRST*’s mission a reality. As a team coach, you join over 80,000 committed and effective volunteers who are key to introducing close to 200,000 young people to the joy of problem solving through engineering.

FIRST provides four programs: the *FIRST* Robotics Competition (FRC) and the *FIRST* Tech Challenge (FTC) for grades 9-12; ages 14-18*, *FIRST* LEGO® League (FLL) for 9 to 14 year-olds, and Junior *FIRST* LEGO League for 6 to 9 year-olds. Also located at *FIRST* headquarters is the research and development facility called *FIRST* Place. *FIRST* Place is integral to game design, new program development, evaluation, and professional development of *FIRST* mentors.

“We want to change the culture by celebrating the mind. We need to show kids that it’s more fun to design and create a video game than it is to play one.”

Dean Kamen,
Founder, *FIRST*

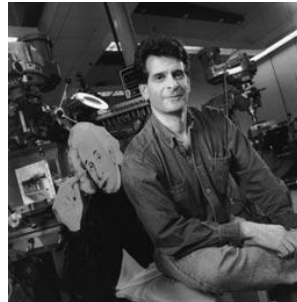

Dean Kamen is President of DEKA Research & Development Corporation; a dynamic company focused on the development of revolutionary new technologies that span a diverse set of applications. As an inventor, physicist, and entrepreneur, Dean has dedicated his life to developing technologies that help people lead better lives. Dean’s proudest accomplishment is founding *FIRST*.

**May include 8th grade students 13 and older who are prepared to enter a high-school program.*

1.3 – WHAT IS THE *FIRST* TECH CHALLENGE?

FIRST Tech Challenge (FTC) is the newest addition to the family of *FIRST* programs. FTC grew out of a need for a mid-level robotics program to transition teams from *FIRST* LEGO League to *FIRST* Robotics Competition. Piloted for two years as the *FIRST* Vex Challenge, FTC became an official *FIRST* program and was renamed *FIRST* Tech Challenge in 2007.

The FTC Competition Kit challenges students' creative problem-solving skills by enabling them to build robots that do amazing things. Students design and construct robotic devices that can be autonomously programmed or operator-controlled to perform various tasks that expand the boundaries of experimental intelligence.

FIRST Tech Challenge teams receive each year's game during a September Kickoff. The game's rules and regulations are provided on the www.usfirst.org website. When you bring dedicated, enthusiastic students and a mentor together, the results can be phenomenal!

1.4 – GRACIOUS PROFESSIONALISM – A *FIRST* CREDO

Dr. Woodie Flowers, National Advisor for *FIRST*, speaks about gracious professionalism in this way: "The *FIRST* spirit encourages doing high-quality, well informed work in a manner that leaves everyone feeling valued. Gracious professionalism seems to be a good descriptor for part of the ethos of *FIRST*. It is part of what makes *FIRST* different and wonderful."

Gracious professionalism can and should mean different things to each of us. It is possible however, to outline some of its meanings:

Gracious attitudes and behaviors are 'win-win.'

Gracious folks respect others and let that respect show in their actions.

Gracious professionals make a valued contribution in a manner pleasing to others and to themselves as they possess special knowledge and are trusted by society to use that knowledge responsibly.

As Woodie says, "In the long run, gracious professionalism is part of pursuing a meaningful life. One can add to society and enjoy the satisfaction of knowing that you have acted with integrity and sensitivity. That's good stuff!"

The *FIRST* Tech Challenge is a student-centered activity and is about giving students a unique and stimulating experience. We want students to learn the value of teamwork and to respect everyone's ideas and contributions to the team. *FIRST* values are about appreciating our differences and learning what those differences add to our lives. *FIRST* programs succeed most fully when team members bring the *FIRST* values they learn back to their communities.

1.5 – THE *FIRST* TECH CHALLENGE – 2009 SEASON

FIRST Tech Challenge teams will participate in the *Hot Shot!* challenge for the 2009 season. Each game match is made up of two distinct types of play – operator-controlled and autonomous. Each tournament features alliances of two teams playing side-by-side on the *Playing Field*. Teams will

compete to score the most points by completing various tasks, including emptying *Ball Chutes* with plastic baseball-size balls and scoring them in *high*, *low*, and *Off-field Goals*. Teams will be challenged by completing tasks during autonomous and *Driver-Controlled Periods* and will be scoring special *Bonus Balls* for double points at the end of a match.

During an exciting build period, teams work as a group to overcome obstacles and meet challenges while learning from and interacting with their peers and adult mentors. Teams work together to build a *Robot* that will be able to successfully complete the challenge set forth at Kickoff. Students come away with a greater appreciation of science and technology and how they might use it to positively impact the world around them. In addition, they cultivate life skills such as planning, brainstorming, collaboration, teamwork, leadership as well as research and technical skills.

Teams are allowed to compete in as many Qualifying Tournaments as they would like but can only qualify to advance to the FTC World Championship at their first three events. The *FIRST* Championship Event in Atlanta, GA is an exciting event where teams from FTC, FRC, and FLL celebrate their accomplishments with other teams, family, and friends. Eligibility requirements for the FTC World Championship will be released after Kickoff on the www.usfirst.org website.

SECTION 2 – THE GAME

2.1 – OVERVIEW

This section describes the *FIRST* Tech Challenge game for the 2009 season, called *Hot Shot!* It also lists the game definitions and game rules.

2.2 – GAME DESCRIPTION

Matches are played on a *Playing Field* initially set up as illustrated in the figures below. Two alliances – one “red” and one “blue” – composed of two teams each, compete in each match. The object of the game is to attain a higher score than your opposing alliance by shooting 9-inch (circumference) plastic balls into the goals in the center of the *Playing Field* (high or low) or in the *Off-field Goals* during the last 30 seconds of the match. The *High Goal* freely spins 360-degrees on a pivot.

In the *Autonomous Period*, balls *Scored* in the center of the *Playing Field* (high or low) goals will be counted and *Scored* at the end of the period. There will also be bonus points awarded to alliances for releasing balls from their color-corresponding *Ball Chutes* during the *Autonomous Period*. *Robots* may only make contact with the color-taped portion of the *Ball Chute Trigger* to release the balls on the *Playing Field*.

There are a total of 80 balls available to both teams as scoring objects in the game. Eight balls are given to each alliance to pre-load onto the *Robots* in any way they want and 60 will be placed in *Ball Chutes* located on each corner of the *Playing Field* – 15 per chute. One special *Bonus Ball* (with a Yellow color) will be given to each team but may only be introduced onto the *Playing Field* in the last 30 seconds of the match.

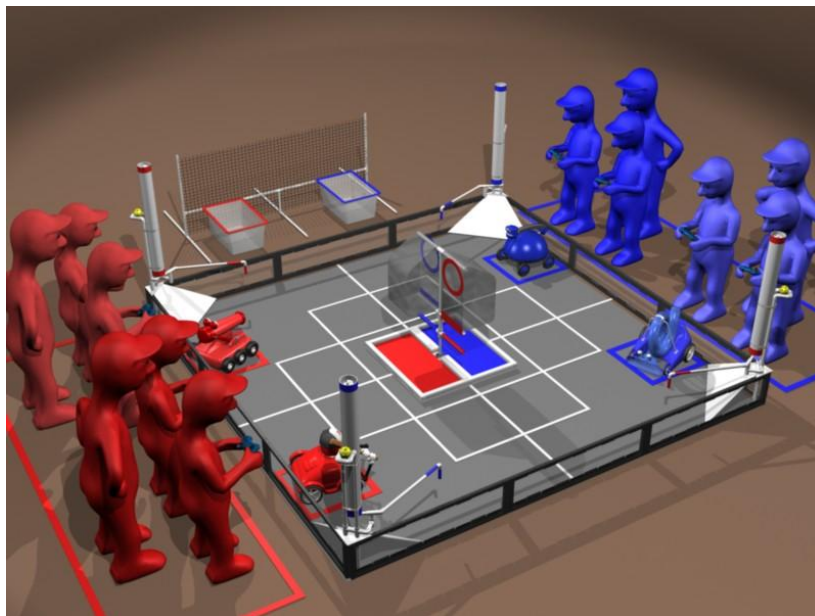

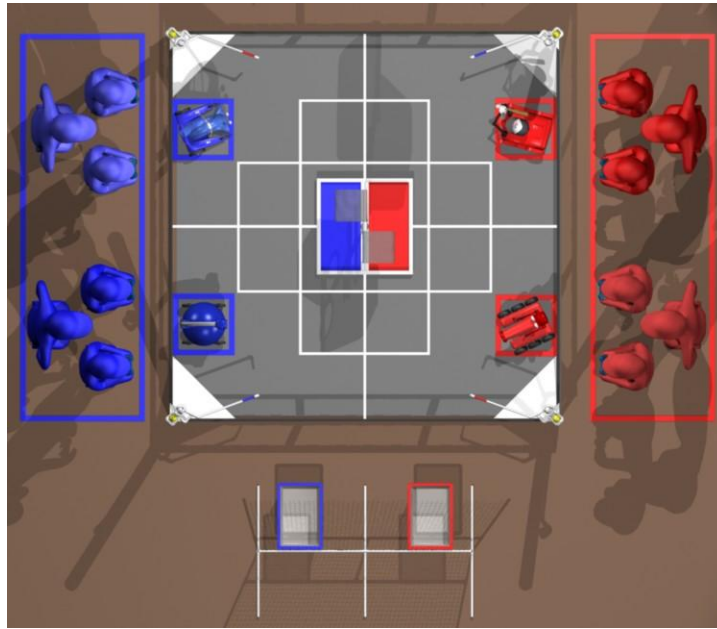

Note: The illustrations in this section of the manual are only provided to give a general visual understanding of the game.

Teams should refer to the official field drawings available at www.usfirst.org under FTC Team Resources for exact field dimensions, a full field BOM and the exact details for field construction. Items listed in the full field BOM are recommended for an official Field Kit. Suitable substitutions are acceptable. Lower cost field options are also provided at www.usfirst.org

2.3 – GAME DEFINITIONS

Alliance – A pre-assigned grouping of two teams that work together for a given match.

Alliance Station – The designated region where the *Drivers* and *Coach* stand or move within during any match.

Autonomous Period – A 30-second period in which the *Robots* operate and react only to sensor inputs and to commands pre-programmed by the team into the onboard robot control system. Human control of the *Robot* is not permitted during this time.

Ball – A scoring element for the 2009 FIRST Tech Challenge game, *Hot Shot!* The ball is a plastic baseball training ball with holes in it. It is made from hard durable plastic and measures 9-inches in circumference (approx. 2.86 inches diameter) and weighs approximately 0.9 ounces. 76 game balls will be white. 4 special *Bonus Balls* will be yellow. *Bonus Balls* will double the total score of all the white balls in the goal it lands in. *Bonus Balls* have no value on their own so if the bonus ball is the only ball in the goal, no points are given.

Ball Chute – A tube standing at each corner of the *Playing Field* to hold Balls that will be released onto the *Playing Field* by the *Robot*. The *Ball Chute* will also be used by a *Coach* to introduce the *Bonus Ball* onto the *Playing Field* during the *End Game*. There are two kinds of *Ball Chutes* on the *Playing Field*:

Near Ball Chute – is immediately next to the corresponding *Drive Teams' Alliance station*.

Far Ball Chute – is across the *Playing Field* from the corresponding *Drive Teams' Alliance station*.

Ball Chute Trigger – The blue or red taped portion of the *Ball Chute* mechanism that enables *Robots* to release the balls onto the *Playing Field*. The PVC coupling between the two taped portions is considered to be part of the *Ball Chute Trigger*.

Center Field Structure – The portion of the *Playing Field* that includes the *High Goal*, *Low Goal* and the 3'x 3' borders and board that enclose those Goals.

Coach – A student or adult mentor designated as the team advisor during the match and identified as the person wearing a “coach” badge or identifying marker.

Competition Area – The area where all the *Playing Fields*, scoring tables, and other event official tables are located.

Drive Team – Up to three representatives (two *Drivers* and one *Coach*) from a legally registered entity with FIRST that is composed of up to 10 students and supported by any number of coaches or mentors.

Driver – A pre-college student team member responsible for operating and controlling the *Robot* and wearing a “Driver” badge or identifying marker.

Driver-Controlled Period – The two-minute time period in which the *Drivers* operate the *Robots* after the *Autonomous Period*.

End Game – The last thirty (30) seconds of the *Driver-Controlled Period* at the end of the match. During the *End Game*, teams can shoot balls into the *Off-field Goals*. *Coaches* may also introduce the four *Bonus Balls* onto the *Playing Field* during this time period by placing them into the top of the *Ball Chutes*.

Field Control System (FCS) – The Field Control System is the computer program that will serve as the communications system between the *Drivers* and the *Robot* during each *Match*. Each *Drive Team* will supply and operate their own FCS for each *Match*.

Match – A *Match* consists of an *Autonomous Period* followed by a *Driver-Controlled Period* for a total time of two minutes and thirty seconds (2:30).

Penalty – A 5-point decrement in the *alliance* score assigned when a deserving violation of the game rules has been identified by a Referee.

Pin / Pinning – One *Robot* preventing the movement in all directions of an opposing *Robot* while in contact with the *Playing Field*, one or more field elements, or another *Robot*. *Pinning* during the *Autonomous Period* will be determined as if the opposing *Robot* were operated under *Driver* control (e.g. *Driver-Controlled Period*) and was not able to move.

Playing Field – The part of the *Competition Area* that includes the 12'x12' field, the *Off-field Goals*, the *Alliance stations*, and optional scoring table.

Robot – Any mechanism which has passed inspection that a team places in their corresponding *Starting Location* prior to the start of a *Match*. A more detailed definition of *Robot* also appears in the *Robot Rules* and *Inspection* sections.

Scored – A ball is *Scored* if the entire ball is a) for the *Low Goal*: in the space extending above the corresponding scoring areas up to the bottom of the spin bar; b) for the *High Goal*: if the ball is supported by the *High Goal* (i.e. it may be partially outside the hole); c) for the *Off-field Goal*: in the space extending infinitely above the corresponding Scoring Area. In all cases, the ball will be *Scored* if it is not touching a *Robot* of the same alliance color as the goal.

Scoring Areas – There are three (3) *Scoring Areas* where balls may be *Scored* – two within the 12'x12' *Playing Field* and one outside the *Playing Field*. Balls will be counted for the corresponding *alliance* color based on where they are *Scored*.

Low Goal – Sits in the base of the center of the *Playing Field* and is divided into a red side and blue side. Each side of the *Low Goal* measures 33" w x 15" d. The *Low Goal* does not include the neutral-colored borders of the goal.

High Goal – A basket-like structure with a 9-inch hole for balls to be *Scored*. Each basket is identified by a red or blue goal face. The bottom of the hole is located 30 inches from the mat of the *Playing Field* (hole center is 34.5 inches from the mat). The hole is located in a 12" w x 24" h sheet of polycarbonate and mounted on a free spinning frame constructed with PVC piping. There is an Infrared Beacon and a 3" wide *alliance*-colored panel at the bottom of the polycarbonate that can be used by the *Robots* for targeting.

Off-field Goal – Two baskets that measure 15" w x 23" d x 15" h and are placed 4 feet away from the front side of the *Playing Field*. Balls can be shot into these goals only during the last 30 seconds of the *Match*. Behind the *Off-field Goal* will be a netted Backstop that will be used to contain balls in the *Competition Area*. The netting is not intended to be a reliable Backstop to bounce balls off to score in the *Off-field Goal*. Teams should expect a large variability in the tautness of the netting.

Spin Bar – A red and blue-taped horizontal PVC pipe that sits between the floor and the bottom of the *High Goal* to allow *Robots* to rotate the *High Goal* (see Field Drawings for details). The *Spin Bar* does not include the PVC cross connector. The color of the *Spin Bar* does not mean that only that *alliance* can touch that side.

Spin Time – The time of the *Match* where it is legal for *Robots* to make contact with the *Spin Bar*. This time is defined as the first 1 minute 30 seconds (1:30) of the *Driver-Controlled Period*. Teams may NOT touch the *Spin Bar* during the *Autonomous Period* or the *End Game*.

Starting Location – The location where teams place their *Robots* before the start of the *Match*. There are two *Starting Locations* per *alliance* on the *Playing Field* located in front of the

corresponding *alliance station*. The *Robot* may start in any orientation anywhere within and including the taped boundary.

2.4 – GAME RULES

2.4.1 – SCORING

A white ball that is *Scored* in the *Low Goal* is worth one (1) point for the corresponding *alliance*.

A white ball that is *Scored* in the *High Goal* is worth five (5) points for the corresponding *alliance*.

A white ball that is *Scored* in the *Off-field Goal* is worth ten (10) points for the corresponding *alliance* only if *Scored* in the *End Game*.

A yellow *Bonus Ball* will double the total points in the goal into which it is scored. The yellow ball itself has no point value, therefore if it is the only ball in the goal at the end of the game, no points will be awarded for that goal.

2.4.2 – SCORING IN AUTONOMOUS MODE

1. Any balls that are *Scored* during the *Autonomous Period* will be counted at the end of the *Autonomous Period*. If those balls stay in the goal throughout the rest of the *Match*, they will be *Scored* a second time.
2. Balls may only score in the *High Goal* or the *Low Goal* during the *Autonomous Period*.
3. If a *Robot* successfully opens a *Ball Chute* releasing all 15 balls onto the *Playing Field* during the *Autonomous Period*, the corresponding *alliance* (based on color of the *Ball Chute*) will score 5 points for the *Near Ball Chute* and 10 points for the *Far Ball Chute*.

2.4.3 – SAFETY RULES

<S1> If at any time the *Robot* operation is deemed unsafe or has damaged the *Playing Field*, field elements, surface, or barriers, by the determination of the referees, the offending team may be disqualified. The *Robot* will require re-inspection before it may again compete.

Note: Teams should pay close attention to other *Robot* Specific Safety Rules outlined elsewhere in other sections of the Game Manual.

<S2> If a *Robot* goes completely out-of-bounds (outside the 12'x12' portion of the *Playing Field*), it will be disabled for the remainder of the *Match*.

Note: The intent is NOT to penalize *Robots* for having mechanisms that inadvertently cross the 12'x12' border walls during normal game play.

2.4.4 – GENERAL GAME RULES

<G1> At the beginning of a *Match*, each *Robot* must not exceed a volume of 18" wide by 18" long by 18" tall. An offending *Robot* will be removed from the *Match* at the Head Referee's discretion.

Alignment devices (templates, tape measures, lasers, etc.) that are not part of the *Robot* may NOT be used to assist with the positioning of the *Robot*.

<G2> Each *Drive Team* shall include up to two *Drivers* and one *Coach*.

<G3> During a *Match*, the *Drivers* and *Coach* must remain in their *Alliance station* and cannot make any contact with the *Playing Field* with the exception of contact described in <SG4>. The first instance of leaving the *Alliance station* will result in a warning, with any following instances resulting in a *Penalty* or disqualification.

<G4> *Drivers* and *coaches* are prohibited from making intentional contact with any game or field object with the exception of the contact described in <SG4>. The first instance of intentional contact will result in a warning, with any following instances resulting in a *Penalty* or disqualification.

<G5> During a *Match*, *Robots* must be remotely operated only by the *Drivers* and/or by software running in the on-board control system. If a *Coach* touches his/her team's *Robot* controls anytime during a *Match*, the *Robot* will be disabled and the team disqualified.

<G6> Scores will be calculated for all *matches* when all objects on the *Playing Field* have come to rest.

<G7> *Robots* may not intentionally detach parts during any *Match*, or leave mechanisms on the *Playing Field*. If a detached component or mechanism is attached to the scoring area and prevents additional scoring of balls, the team will be disqualified. Multiple infractions may result in disqualification for the entire competition.

<G8> Strategies and mechanisms aimed solely at the destruction, damage, tipping over, or entanglement of *Robots* or *Scoring Areas* are not in the spirit of the *FIRST* Tech Challenge and are not allowed. However, *Hot Shot!* is a highly interactive contact game. Some tipping, entanglement, and damage may occur as a part of normal game play. If the tipping, entanglement, or damage is ruled to be intentional, the offending team may be disqualified for that *Match*. Repeated offenses could result in a team being disqualified from the remainder of the competition.

<G9> A *Robot* cannot *Pin* another *Robot* for more than five seconds. If a referee determines this rule to be violated, the offending *alliance* will receive a *Penalty* and the offending *Robot* may be disabled for the *Match*. A *Robot* cannot incur a *Pinning Penalty* during Autonomous Mode. If a *Pinning* occurrence happens during Autonomous Mode, the first action done by the offending *Robot* during the *Driver-Controlled Period* must be to back away from the pinned *Robot* or a *Penalty* will be assessed.

<G10> The actions of an *alliance* or their *Robots* shall not cause an opposing *alliance* or *Robot* to break a rule and thus incur penalties. Any rule violations committed by the affected *alliance* shall be excused, and no penalties will be assigned.

<G11> *Robots* must be designed to permit easy removal of balls from any grasping, containing, or holding mechanism without requiring that the *Robot* have power after the *Match*.

<G12> Field tolerances may vary by as much as +/-1.0" and ball tolerances may vary as much as +/- 0.125" and +/- 0.25 ounces. Teams must design their *Robots* accordingly.

2.4.5 – *HOT SHOT!* SPECIFIC GAME RULES

<SG1> At the beginning of each *Match*, each *alliance Robot* must be placed onto the *Playing Field* in the *Starting Location*.

- a. During the *Qualifying Matches*, the red *alliance Robots* must be placed on the *Playing Field* first.
- b. During the *Elimination Matches*, the lower seeded (i.e. 3rd seed is lower than 2nd seed) *alliance Robots* must be placed on the *Playing Field* first.

<SG2> Prior to the start of each *Match*, each *alliance* will have eight (8) balls available to preload into their *Robots*.

- a. A ball is considered to be legally preloaded if it is touching the *Robot* and not touching any part of the field mat, other field elements, or border wall.
- b. The preloaded balls can be loaded onto the *Robots* in any number not to exceed eight (8).
- c. Balls not preloaded will remain out of play for the duration of the *Match*.

<SG3> There are 15 Balls set in each of the *Ball Chutes* before the beginning of the *Match*. Teams are not allowed to touch or reposition the balls or the *Ball Chute Trigger* in any way prior to the start of a *Match*. Repeated violation of this rule may result in team disqualification.

<SG4> During the *End Game* portion of the *Match*, the *Coach* for each team may introduce the *Bonus Ball* onto the *Playing Field*. The only means of doing this is through the top of either of the two *Ball Chutes* closest to the team's *Alliance station* (regardless of ownership of the *Ball Chute*). Only one *Bonus Ball* may be introduced per *Ball Chute*. Violations of this rule will result in a *Penalty* for the team and any points *Scored* by the penalized team with the corresponding *Bonus Ball* will be negated.

<SG5> Scoring in the *Off-field Goals* may only occur during the *End Game* portion of the *Match*, Violations of this rule will result in a *Penalty* for the team and any points *Scored* will be negated.

<SG6> Balls that leave the 12'x12' area of the *Playing Field* will be placed back in play at the earliest safe opportunity by a designated game official unless it has left play during the *End Game*. Balls will be placed onto the *Playing Field* at the approximate location where it exited. *Drive Teams* are not allowed to return balls onto the *Playing Field*. Violation of this rule will result in a *Penalty* for the team and may result in a team disqualification.

<SG7> *Robots* may only make intentional contact with the *Spin Bar* and not any other portion of the *High Goal* during the *Teleop* portion of the *Match*. Touching any other part of the *High Goal* will result in a *Penalty* for the team. Touching the *Spin Bar* during the *Autonomous Period* or during the *End Game* will result in a *Penalty* for the team.

<SG8> *Robots* may only make intentional contact with the taped portion of the *Ball Chute Trigger* and not any other portion of the *Ball Chute*. Touching the non-taped portion of the *Ball Chute Trigger* or other parts of the *Ball Chute* will result in a *Penalty* for the team. However, it is legal for a *Robot* to touch the PVC elbow that is between the two taped portions of the trigger.

<SG9> In the event a single ball meets the definition of *Scored* in more than one goal at the conclusion of either period, that ball will count only once for the highest point value possible.

<SG10> Removing (de-scoring) balls from only the *Low Goal* will be allowed. Intentional de-scoring of balls from any other goal will result in a team disqualification.

<SG11> Ball and Goal Blocking Rules:

- a. A ball that has been fully released from a *Robot* and is above 18" from the *Playing Field* (i.e. the ball is not in contact with any part of the *Robot* that released it) with the intention of scoring into any of the Goals may NOT be blocked by an opposing *alliance's Robot*. Each blocked ball will be awarded the points it would have received had it *Scored*.
- b. Blocking any Goal by a mechanism of a *Robot* that is located within the *Center Field Structure* is not allowed. Each blocked ball will be awarded the points it would have received had it *Scored* and repeated offenses of this rule will result in a team disqualification.
- c. Mechanisms designed for the sole purpose of blocking balls is prohibited (i.e. square panels that block the *High Goal*) even if the *Robot* is located outside of the *Center Field Structure* are illegal. *Robots* that violate this rule will not pass inspection (see Rule <R2>d).

2.4.6 – *HOT SHOT!* PENALTY SUMMARY

The following table shows the possible rule violations and their ramifications:

Violation	Ramification	Rule
<i>Drive Team</i> outside of <i>Alliance station</i>	Warning; followed by 5 points per offense May lead to disqualification for <i>Match</i>	<G3>
<i>Drive Team</i> contacts field or game object	Warning; followed by 5 points per offense May lead to disqualification for <i>Match</i>	<G4>
<i>Coach</i> touches controls	<i>Robot</i> disabled and team disqualified for <i>Match</i>	<G5>
<i>Robot</i> intentionally detaches parts in scoring area	<i>Robot</i> disabled and team disqualified for <i>Match</i> . Multiple infractions may result in disqualification for the entire competition.	<G7>
Intentional tipping, entanglement, or damage	<i>Robot</i> disabled and team disqualified	<G8>
<i>Pinning</i>	5 points per offense May lead to disqualification for the <i>Match</i>	<G9>
<i>Bonus Ball</i> introduced too early or not through <i>Ball Chute</i>	5 point <i>Penalty</i> and any score with that <i>Bonus Ball</i> negated	<SG4>
Scoring in <i>Off-field Goals</i> too early	5 point <i>Penalty</i> per occurrence and any score with the offending ball(s) negated	<SG5>
<i>Drive Team</i> returning balls to <i>Playing Field</i>	5 points per offense May lead to disqualification for the <i>Match</i>	<SG6>
<i>Robots</i> contacting the <i>High Goal</i> instead of the <i>Spin Bar</i>	5 points per offense	<SG7>
<i>Robots</i> contacting the <i>Spin Bar</i> during autonomous	40 points per offense	<SG7>

Violation	Ramification	Rule
<i>Robots</i> contacting the non-taped portion of the <i>Ball Chute Trigger</i> or mechanism	5 points per offense	<SG8>
Intentional de-scoring of balls from the <i>High Goal</i>	Disqualification for the <i>Match</i>	<SG10>
Blocking a ball that has been released from a <i>Robot</i> or the <i>High Goal</i>	Each blocked ball will be awarded the points it would have received had it <i>Scored</i> .	<SG11>a
Blocking the <i>High Goal</i> while on the <i>Center Field Structure</i>	Each blocked ball will be awarded the points it would have received had it <i>Scored</i> . May lead to disqualification for the <i>Match</i>	<SG11>b
Blocking Mechanisms	Disqualification	<SG11>

SECTION 3 – THE TOURNAMENT

3.1 – OVERVIEW

The *FIRST* Tech Challenge will be played in a tournament format. Each tournament will include practice, qualifying, and *Elimination Matches*. After the *Qualifying Matches*, teams will be ranked based on their performance. The top teams will then participate in the *Elimination Matches* to determine the event champions.

This section provides a general summary regarding a *FIRST* credo, mascots/uniforms, recommended items and equipment for teams to bring, pit rules, event schedules, registration, practice rules/time slots, and *Robot* inspections. Please read the following to get a "feel" for competition schedules, registration procedures, practice times, and *matches*.

3.2 – TOURNAMENT DEFINITIONS

Alliance Captain – A student chosen to represent their team during *Alliance Selection* for the final *Elimination Matches*.

Alliance Selection – The process of choosing the permanent alliances for the *Elimination Matches*.

Elimination Match – A match used to determine the Winning Alliance. Alliances of two or three teams face off in a series of matches, with two teams per alliance playing in each match. The first alliance to win two matches will proceed to the next round.

Practice Match – A match used to provide time for teams to get acquainted to the official *Playing Field*.

Qualifying Match – A match used to determine the rankings for the *Alliance Selection*. Alliances compete to earn *Qualifying Points* and *Ranking Points*.

Qualifying Points (QPs) – The first basis of ranking teams. *Qualifying Points* are awarded for winning (two points) and tying (one point) a *Qualifying Match*.

Ranking Points (RPs) – The second basis of ranking teams. *Ranking Points* are awarded in the amount of the final score of the losing alliance in a *Qualifying Match*. *Ranking Points* are used as the tiebreakers when teams have equal *Qualifying Points*.

Surrogate Match – An additional *Qualifying Match* for some teams depending on the number of teams in the tournament. A *Surrogate Match* will not count in the standings for *Qualifying Points* or *Ranking Points* to the teams that are marked as playing as surrogates. However, these matches are very important in the entire standings and should be played by all as if they were regular *Qualifying Matches*.

3.3 – TOURNAMENT EVENT AGENDAS

Schedules will be available through your local FTC Affiliate Partner prior to or at your tournament.

3.4 – COURTESIES AND RULES

You will hear the expression Gracious Professionalism often throughout your involvement in the *FIRST* Tech Challenge. One of our main goals is to encourage all team members to conduct themselves with kindness, consideration, and sharing.

We hear heartwarming stories of teams sharing parts, helping to build and/or repair competing *Robots*, and helping rookie teams avoid preventable pitfalls. These are examples of some side benefits of being involved with this organization.

The pit is where the behind-the-scenes action takes place. The *FIRST* staff and volunteers want you to enjoy the competition. Please read the rules below so everyone can work and compete in a safe, sportsmanlike, friendly, and orderly manner. Please follow courtesy rules while in the pit as well as in the audience. Please help to make the audience comfortable.

Bands:	No live bands in the audience or pit.
Battery Safety:	Charge in an open, well-ventilated area.
Fire Extinguishers:	Located at the pit administration station and in the <i>Competition Area</i> .
Food:	You should check with the event organizer before bringing food to an event, as some venues will not allow outside food on-site due to contracts and agreements.
Music/Noise:	No loud music, audio systems, whistles, banging sticks, blow horns, etc. They prevent teams from hearing important announcements. Power may be shut off and/or noise makers confiscated.
Internet/Wireless Network Access:	Teams may not set up a wireless network for communication between themselves or amongst the teams. Internet access for the teams will be at the discretion of the Tournament Director.
Team Safety Captain:	Each team appoints a safety captain who will help maintain safety at events, especially in the pit. He or she will remind attendees about safety rules listed below.
Safety Glasses:	All team members and onlookers must wear safety glasses in the pit and near the <i>Competition Area</i> . If you wear prescription glasses, you must wear safety goggles over them or attach safety side shields to them. Teams are required to bring enough safety glasses/goggles to supply its team members and its guests.
Running:	There will be no running in the pit.
Painting:	There will be no painting in the pit.
Sales:	Because of site regulations/contracts, <i>FIRST</i> cannot allow teams or individuals to sell items, such as T-shirts, pins, etc., at any events.

Seat Saving:	Not allowed, we need seats to get the public comfortable and interested.
Soldering, Gluing, Brazing, or other Large Power Tools:	At the discretion of the Tournament Director, these items are not allowed in the pit areas or at the competitions. Contact your Affiliate Partner for alternatives.

3.5 – EYE PROTECTION AND SAFETY

FIRST requires all teams to bring and supply safety glasses for its members and guests for each competition. Students and adult team members and guests must wear them to protect their eyes while working on the *Robot*, when observing *Robot* building/repair work, and while competing.

Operators, players, and coaches will not be allowed in the *Competition Area* without them. Regular glasses and sunglasses do not qualify as safety glasses. If you wear prescription glasses, you must wear safety goggles over them or attach safety side shields.

3.6 – EVENT DAY OVERVIEW

An overview of the event and tournament will generally follow the following agenda:

1. Team Registration
2. *Robot* and Software Inspection
3. Judge's Interviews
4. Practice Matches
5. Opening Ceremony
6. *Qualifying Matches*
7. *Alliance Selection*
8. *Elimination Matches*
9. Awards and Closing Ceremony

3.6.1 – TEAM REGISTRATION

As a team arrives at the venue, the *Coach* or other adult mentor should register the team with the tournament officials. During registration, the *Coach* will receive a packet of information for the team that may include team badges, a judging schedule, a map of the facilities and pits, and other information that is very important to the teams. The *Coach* should review all the material to make sure the packet is complete. At this time, the team should set up their Pit area and get familiar with the venue such as where the practice and *Playing Fields* are, where judging will take place, and understand the schedule.

3.6.2 – ROBOT AND SOFTWARE INSPECTION

FTC *Robots* will be required to pass hardware and software inspections before being cleared to compete. This inspection will ensure that all FTC *Robot* rules and regulations are met. Initial inspections will take place during team registration/practice time. A copy of the official FTC "Robot Inspection

Sheet” is located in another section. The “Robot Inspection Sheet” should be used as a guide to pre-inspect the *Robot*.

3.6.3 – JUDGE’S INTERVIEWS

At *FIRST* Tech Challenge events, there are generally three parts to the judging process: 1) interview with judges, 2) evaluation of performances, and 3) evaluation of the Engineering Notebook. Each team will have a ten to fifteen minute “fact finding” discussion/interview with a panel of two or three judges. The Judge’s Interviews generally take place before any *Qualifying Matches* take place so that the entire team may be interviewed. When teams arrive at the event, the interview schedule should be included in the registration materials. Make sure you know when your team will be interviewed and arrive to the interview room early. Please have at least two student team representatives available; the entire team/robot is encouraged to participate.

3.6.4 – PRACTICE MATCHES

At the event, *Practice Matches* may be played in the morning during the team registration time until the *Drivers’* meeting begins. Every effort will be made to equalize practice time for all teams, but may also be conducted on a first-come, first-served basis. These matches may be *Scored*, but the scores do not affect team ranking.

3.6.5 – OPENING CEREMONY

The Opening Ceremony is the official kickoff of the event’s activities for the teams, the fans, and the public. During the Opening Ceremony, a tournament official or the emcee will welcome the teams and the public, introduce dignitaries and other special guests, and introduce the judges and the referees. Then the game will be described (usually with a video) and the national anthems of all the teams’ countries will be played. Immediately after, the first *Qualifying Match* takes place.

If your team is in any of the first four matches on the day of your event, volunteers will ask you to line up before the opening ceremonies. Matches begin right after its conclusion. Please, make sure your team is on time in case you have an early match.

3.6.6 – *QUALIFYING MATCHES*

The *Qualifying Match* schedule will be available prior to opening ceremonies on the day of the event. This schedule will indicate alliance partners and match pairings. It will also indicate the alliance’s color – red or blue – for the matches. These matches will start immediately after the Opening Ceremonies in accordance with the *Qualifying Match* schedule. The queue team will work together throughout the day to line up teams for the matches and maintain the schedules. It is very important to pay attention to the match schedule and listen for announcements throughout the day. You will need to know when you will compete, find out the number of the ending match before lunch, and which match is the last match of the tournament day.

Teams will be randomly assigned an alliance partner to compete with against two other randomly assigned opponents for each *Qualifying Match*. All teams will be *Scored* based on the same number of *Qualifying Matches*. In some cases, a team will be asked to play a *Surrogate Match* that will not count towards their standings during the event. This additional match will be denoted on the match schedule and/or announced to the teams prior to the start of the *Qualifying Matches*.

At the conclusion of each match, *Qualifying Points (QP)* will be awarded:

Winning teams of a *Qualifying Match* receive two (2) QP.

Losing teams of a *Qualifying Match* receive zero (0) QP.

If a *Qualifying Match* ends in a tie, all four teams receive one (1) QP.

If a team is disqualified they receive zero (0) QP.

Teams will also receive *Ranking Points (RP)* based on the following:

The number of *Ranking Points* assigned for each match, is that of the losing alliance's score.

In the event of a tie, both alliances will receive the same RP (equal to the tie score).

If a team is disqualified they receive zero (0) RP.

If both teams on an alliance are disqualified, the teams on the winning Alliance will be awarded their own score as their RP for that match.

For a *Qualifying Match*, if no member of a team is present in the *Alliance Station* at the start of a match, that team is declared a "no show" and will receive zero (0) QP and zero (0) RP.

At the conclusion of all *Qualifying Matches*, the teams will be ranked from first through last on the basis of their total *Qualifying Points (QPs)*. If multiple teams have the same QP total, then teams will be ranked on the basis of their total *Ranking Points (RPs)*. If multiple teams have the same RP total as well, then teams will be ranked on the basis of their highest match score. If still tied, the next highest match score will be used until the tie is broken. In the unlikely event that there is still a tie based on identical match scores, then the teams will be ranked by a random electronic draw.

3.6.7 – ALLIANCE SELECTION

The number of teams in the *Elimination Matches* will be based on the number of teams in the tournament and the schedule of the day determined by the tournament director. If there are 21 or more teams in the tournament, the *Elimination Matches* will consist of alliances of 3 teams each. If there are 20 teams or less, then the alliances will consist of 2 teams each. There will be a total of four (4) alliances that will compete in the Elimination Bracket.

The *Alliance Selection* process will consist of a number of rounds of selections, such that all *Alliance Captains* will form *Elimination Match* alliances consisting of the requisite number of teams. These alliances will participate in a ladder-type tournament to determine the event's Champion Alliance. The *Alliance Selection* process is as follows:

Each team will choose one student to act as the team’s representative. These representatives will proceed to the *Competition Area* at the designated time to represent their teams in the *Alliance Selection*.

In order of tournament ranking, the student representative of the highest ranked team not already in an alliance will be asked to step forward as the *Alliance Captain* to invite another available team to join their alliance.

A team is available if they are not already part of an alliance, or have not already declined an alliance invitation. If the team accepts, it is moved into that alliance. If a team declines, the CANNOT be invited into another alliance, but are still available to select their own alliance if the opportunity arises. If a team declines, the *Alliance Captain* from the inviting team must then extend an invitation to another team.

The process continues until all *Alliance Captains* have been designated and chosen one alliance partner.

If there are more than 20 teams, the same method is used for each *Alliance Captain’s* second choice (the third member of the alliance) from highest seed to lowest seed. Any teams remaining after the lowest seeded captain makes their choice will not compete in the *Elimination Matches*.

3.6.8 – ELIMINATION MATCHES

The *Elimination Matches* are very exciting in where the alliances determine who will be the Champion of the event. The matches are played in a seeded ladder format where the top seed goes up against the lowest seed, 2nd best seed vs. the 2nd lowest seed, and so on.

In the *Elimination Matches*, teams do not get *Qualifying Points*; they get a win, loss or tie. Within each bracket of the *Elimination Match Ladder*, matches will be played to determine which alliance advances. The advancing alliance is the first one to win two matches. Any tied matches will be replayed until one alliance has two wins, and advances. The winners of each of the *Elimination Matches* continue to play until the champion is determined. An example tournament bracket appears here:

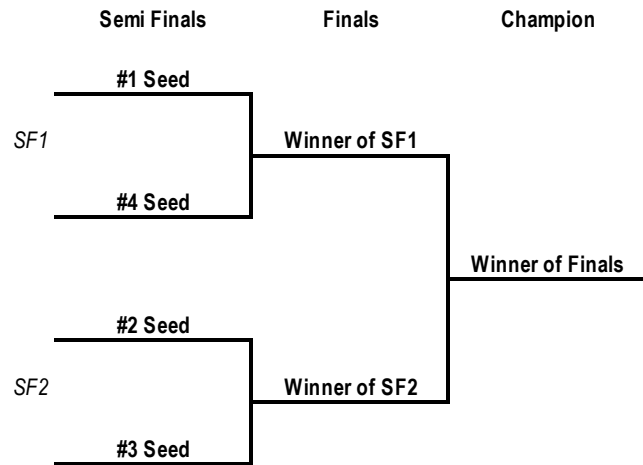

During each round of the *Elimination Matches*, two teams from an alliance will compete on the *Playing Field*. If the alliance has three teams on it, the team that sits out the first match in an elimination series must play in the second match, with no exceptions. If the teams play more than two matches, any combination of two alliance *Robots* may be used. Teams should consider the robustness of the *Robots* when picking alliance partners.

If a team is disqualified during an *Elimination Match*, then their entire alliance is disqualified, and the match will be recorded as a loss. Prior to each *Elimination Match*, the *Alliance Captain* must let the referee know which two teams will be playing in the upcoming match.

3.6.9 – AWARDS AND CLOSING CEREMONY

The Awards and Closing Ceremony celebrates the accomplishments of the teams and how they all did during the event. The ceremony will begin as soon as the last match is played, however some awards may be given out earlier in the event day (depending on the tournament officials). During the ceremony, all teams will be recognized for their accomplishments as the awards are handed out. The Winning Alliance teams and the Finalist Alliance teams will also be recognized. Finally, the Inspire Award winner will also be announced.

Depending on whether the event is a scrimmage, a qualifying tournament, or a championship, the tournament officials will determine the advancement criteria. Generally, the Inspire Award winner and the Winning *Alliance Captain* will advance to the next round of competitions. Other teams may be chosen to advance to the next round. The advancement criteria will be announced to the teams prior to the start of the event.

3.7 – TOURNAMENT RULES

<T1> Referees have ultimate authority during the competition. **Their rulings are final.**

- a. The referees will not review any recorded replays.
- b. Any questions for the referees must be brought forward by one student *Drive Team* member within the time period of two (2) matches following the disputed match.
- c. Team members are not allowed onto the *Playing Field* for any reason other than to place or retrieve their *Robots*. Inspection of the *Playing Field* elements by team members for the express purpose of determining scoring is prohibited.
- d. Individuals and Teams that violate this rule will be subject to possible team punishments including anywhere from match disqualification up to and including removal from the tournament.

<T2> The only people permitted on the *Playing Field* are the three *Drive Team* members who are identified by the *Drive Team* badges. These badges are interchangeable within a team.

<T3> There are no time outs in the qualifying rounds. In the elimination rounds, each alliance will be allotted ONE time out of no more than three minutes. The matches must progress according to schedule.

- a. If a *Robot* cannot report for a match, at least one member of the team should report to the *Playing Field* for the match.

<T4> Teams will be guaranteed a minimum of five minutes between matches.

<T5> All team members and their guests, including coaches, must wear safety glasses or prescription glasses with side shields while in the pits or *alliance stations* during matches.

NOTE: *FIRST* requires all teams to bring and supply, for each competition, ANSI-approved non-shaded safety glasses for its team members, mentors, and guests. For our purposes, amber lenses that allow for better/brighter vision are considered tinted, not shaded, and their use is allowed at *FIRST* events. Sunglasses or deeply shaded safety glasses used in our indoor event environment are not acceptable.

3.8 – TEAM SPIRIT

Competing as a team is fun as well as rewarding. Part of the pleasure and reward of being a team member is the way the team stylizes itself with team T-shirts, trading buttons, hats, cheers, cheerleaders, and costumes.

3.8.1 – TEAM STYLING

When deciding on a team name or acronym, consider how you can work a theme around it to make your team more fun and recognizable. Refer to Section 8: Team Resources for information.

3.8.2 – BANNERS AND FLAGS

Sponsors provide *FIRST* with banners so we can display them in specified areas as a way of thanking them for their generosity. We encourage teams to bring team flags and/or sponsor banners, but we ask that you adhere to the following:

Do not use them to section off seating. Saving group seats is not permitted.

Hang banners in your pit station only, not on the pit walls.

You may bring banners to the *Competition Area*, but please do not hang them there. This area is designated for official *FIRST* sponsors' banners.

3.8.3 – SPECTATORS AND ETIQUETTE

Teams are permitted to have 2 *Drivers* and 1 *Coach* (the *Drive Team*) at the *Playing Field* during their scheduled matches. Spectators are not allowed on the *Playing Field* at any time and must remain outside of the designated *Competition Area*. Some events may provide media passes for one additional team member to gain access to a designated "media area". Access to this area is only permitted with a media pass and only while the media representative's team is on the *Playing Field*. Spectators blocking the sidelines or accessing the media area without a pass will be asked to move. Repeated violations of this rule may cause the associated team to be disqualified.

3.8.4 – SCOUTING

This information has been provided by the 2007 FRC Chairman's Award winners, FRC Team #365, the Miracle Workerz:

Teams use all different methods to record information about other teams – paper, computer, hand-held PDAs, etc. Use whatever method is most comfortable for your team. Scouting is important to determine how you complement other teams in your alliance and how you match up against your

opponents. No matter how you record it, focus on information, which will be useful to your team when you meet your alliance partners to discuss strategy.

Some possible areas to gather information include:

CAPABILITIES – what can the robot/team do and what can't it do?

STRATEGIES – what does the robot / team do during the match? How do they play the game?

PERFORMANCE – how well does the robot / team do what it attempts? What are the robot's strengths and weaknesses?

AUTONOMOUS – what does the robot do in autonomous mode? Does the team have multiple program options?

The more data points you can collect on strategies and performance, the better understanding you will have of a given team. Many teams use a paper system to record this information. Information on Capabilities can be obtained by visiting the team / robot in the pit area.

SECTION 4 - THE ROBOT

4.1 – OVERVIEW

This section provides rules and requirements for the design and construction of your *Robot*. A *FIRST* Tech Challenge *Robot* is a remotely operated vehicle designed and built by a registered *FIRST* Tech Challenge team to perform specific tasks when competing in *Hot Shot!* Prior to competing at each event, all *Robots* will have to pass an inspection. Refer to Section 9 for the Robot Inspection Guidelines and Inspection Checklist.

4.2 – ROBOT RULES

There are specific rules and limitations that apply to the design and construction of your *Robot*. Please ensure that you are familiar with each of these *Robot* rules before proceeding with *Robot* design.

<R1> Only ONE *Robot* will be allowed to compete per team in the *FIRST* Tech Challenge. Though it is expected that teams will make changes to their *Robot* at the competition, a team is limited to only ONE *Robot*.

- a. It is against the intent of this rule to compete with one *Robot* while a second is being modified or assembled.
- b. It is against the intent of this rule to switch back and forth between multiple *Robots* during a competition.

<R2> Every *Robot* will be required to pass a full inspection before being cleared to compete. This inspection will ensure that all FTC *Robot* rules and regulations are met. Initial inspections will take place during team registration/practice time.

- a. If significant changes are made to a *Robot*, it must be re-inspected before it will be allowed to compete.
- b. All *Robot* configurations must be inspected before being used in competition.
- c. Teams may be requested to submit to random spot-inspections by event personnel. Refusal to submit will result in disqualification.
- d. Referees or inspectors may decide that a *Robot* is in violation of the rules. In this event, the team in violation will be disqualified and the *Robot* will be barred from the *Playing Field* until it passes re-inspection.

For further information on the inspection process please refer to Section 9, Robot Inspection Guidelines

<R3> The following types of mechanisms and components are NOT allowed:

- a. Those that could potentially damage *Playing Field* components.
- b. Those that could potentially damage other competing *Robots*.
- c. Those that contain hazardous materials (e.g. mercury switches).
- d. Those that pose an unnecessary risk of entanglement.
- e. Those that are designed to flip or tip over goals or other *Robots*.

- f. Those that contain sharp edges.

<R4> At the beginning of any match, the maximum allowed size of a *Robot* is 18" x 18" x 18".

- a. During inspections, *Robots* will be placed into a "sizing box" which has interior dimensions matching the above size constraints. To pass inspection, a *Robot* must fit within the box as defined in the Robot Inspection Section.
- b. *Robots* may expand beyond their starting size constraints after the start of a match but this year there are limitations to how far a *Robot* can extend. The purpose of this rule is to prevent a *Robot* from becoming a safety hazard to off-field personnel or causing damage to the field elements. Therefore, beginning at 10" above the tile surface, *Robots* may not extend more than 10" horizontally from the starting size of the *Robot* (see drawing below). There is no limit as to how far a *Robot* may extend vertically.

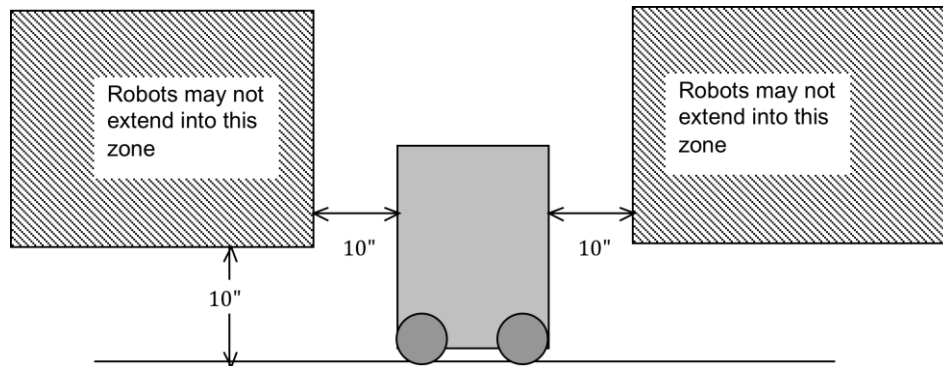

- c. Any restraints used to maintain starting size (i.e. zip ties, rubber bands, string, etc.) MUST remain attached to the *Robot* for the duration of the match.

<R5> *Robot* construction is constrained to the following:

- a. Any part from the TETRIX system with the following constraints:
- No more than eight (8) TETRIX 12V DC drive Motors
 - No more than twelve (12) TETRIX Servos
 - Exactly one (1) 12V Rechargeable NiMH Battery Pack. This battery pack may only be used to power the *Robot* through the HiTechnic DC Motor and Servo Controllers. This battery pack must be identical to those supplied in the kit of parts. (Note: the TETRIX™ battery pack is custom designed with an internal 20 amp protection circuit. Use of any other battery could result in permanent damage to the NXT components and is not allowed). Battery packs are NOT allowed to be used as ballast.
 - A total of no more than four (4) HiTechnic DC Motor or Servo Controllers (in any combination)
 - The TETRIX R/C Controller (Product Id W34243), the Infrared Electronic Ball (Product Id W991458) and the TETRIX Speed Controller (Product Id W34244) are NOT allowed.
 - The TETRIX AA Battery Holder is not allowed.
 - The Permatex Super Lube provided by the TETRIX system may be used only to reduce friction with the *Robot*. Lubricants shall not be allowed to contaminate the *Playing Field* or other *Robots*.
- b. Any LEGO building element with the following constraints:
1. Exactly one (1) NXT Controller must be used

2. The NXT controller must be powered either by the NXT rechargeable battery pack or six (6) AA batteries.
 3. No more than three (3) NXT Motors may be used.
 4. Non-NXT electrical elements are not allowed, with the exception of RCX sensors.
 5. LEGO pneumatic elements are allowed. Teams may not modify LEGO pneumatic elements to attempt to change the working pressure limits of the elements.
 6. Any LEGO Approved NXT sensor (as indicated by the LEGO Mindstorms NXT Certified – Hardware label)
 7. Any NXT compatible sensor from HiTechnic, including the NXT Touch Sensor Multiplexer, NXT Sensor Multiplexer and the NXT prototype boards (both solderable and solderless)
 8. No more than one (1) LEGO Power Function Battery Box may be used. It may be used only in conjunction with and to power the NXT Sensor Multiplexer(s).
 9. LEGO-Approved NXT extension cables. Approved cables are currently only available from LEGO and HiTechnic.
- c. The following additional components may also be used:
1. Polycarbonate plastic sheet (e.g. Lexan), not to exceed 24" x 24" in area or maximum dimension and not greater than 0.10" thick.
 2. Kydex plastic sheet, not to exceed 24" x 24" in area or maximum dimension and not greater than 0.040" thick (1 mm).
 3. ABS plastic sheet, not to exceed 24" x 24" in area or maximum dimension and not greater than 0.0625" thick.
 4. PETG (aka Vivak® Copolyester Sheet) not to exceed 24" x 24" in area or maximum dimension and not greater than 0.080" thick.
 5. Polycarbonate glue/cement is allowed, only for the joining of polycarbonate pieces. Use of polycarbonate glues/cements may or may not be allowed in the pits at tournaments based on site-specific rules or requirements.
 6. Aluminum, not to exceed 24" x 24" in area or maximum dimension and not greater than 0.0625" thick
 7. Rope or cord any length, not to exceed 0.125" in diameter
 8. Plastic-coated wire rope 0.03125" diameter or smaller. Compatible compression sleeves, clamps and hardware may also be used only in conjunction with the plastic-coated wire rope.
 9. Non-Slip Pad, not to exceed 24" x 24" in area or maximum dimension (e.g. McMaster Carr Part #69275T54 or Home Depot SKU #134555)
 10. PVC piping (of any schedule) 3" inside diameter or smaller, not to exceed 36" in total length
 11. Commercial PVC couplings are not allowed.
 12. PVC cement and cleaner (only for gluing PVC). Use of PVC cements and cleaners may or may not be allowed in the pits at tournaments based on site-specific rules or requirements.
 13. Compatible mechanical fasteners (nuts, bolts, screws, etc.)
 14. Mechanical fasteners may be secured using Loctite® or a similar thread-locking product. .

15. Rubber bands (size #32 or smaller, i.e. 0.125" thick & 3" in circumference)
 16. Surgical Tubing 0.25" OD or smaller not to exceed 24" total length
 17. Electrical tape and/or heat shrink tubing used only for insulation of electrical connections.
 18. Universal Security Clips to hold PWM connections together, such as #2870 found at <http://www.maxxprod.com/mpi/mpi-3.html>
 19. PWM extension cables. These cables may either be purchased from a vendor or fabricated by the team.
 20. Any material strictly used as a color filter for a Light Sensor.
 21. Hook and loop (e.g. Velcro, 3M Dual Lock) fastener may be used. The fastener may not be used as tape.
 22. Non-Metallic Cable ties (also known as Zip Ties) up to 11" in length may be used.
 23. The packaging, manual binders, Styrofoam, cardboard, plastic bags, etc. from the TETRIX and/or LEGO kits are NOT included and CANNOT be used for *Robot* construction. Only the TETRIX and LEGO parts themselves are allowed.
- d. For the HiTechnic NXT Prototype Board the following constraints apply:
1. All power used in the circuits connected to the NXT Prototype Board must be derived from the power connections provided within the board. No batteries or external power sources are allowed.
 2. Circuits may connect only to the named connections provided by the NXT Prototype Board (i.e. A4-A0, B5-B0, 3V, 4V, 9V, 5V, GND)
 3. Communication to the NXT Controller may only occur through the included NXT connector.
 4. Sensors connected via the NXT Prototype Board may be distributed throughout the *Robot*, they do not need to be physically attached to the NXT Prototype Board.
 5. Additional circuit boards may be connected to the NXT Prototype Board as needed.
 6. The processor included in the NXT Prototype Board may not be reprogrammed
 7. Circuits included as part of the HiTechnic NXT Prototype Board may not cause interference with any *Robot* on the *Playing Field*, any part of the field management system or any game element.
 8. Only visible light LEDs may be connected to the Prototype Board. These visible LEDs may only be used as a cueing signal for the team or for decoration. If used, the purpose must be demonstrated during inspection.
- e. The *Robot* must be designed to be controlled by no more than two (2) Logitech Gaming Controllers
- f. Teams may add non-functional decorations from parts not on the above list, provided that these parts are non-functional, do not affect the outcome of the match, are not hazardous to themselves or other teams, and are in the spirit of "Gracious Professionalism".
- g. Vex parts of any type are not allowed.
- h. No additional components may be used.

<R6> All parts that are used must be tracked through a Bill of Materials (BOM). This list can be included in your Engineering Notebook. The BOM should be detailed enough to allow a copy of the *Robot* to be built using only the listed parts.

<R7> During inspections if there is a question about whether something is an official TETRIX or LEGO component, a team will be required to provide documentation to an inspector, which proves the component's source. Such types of documentation include receipts, part numbers, or other printed documentation.

<R8> No more than one NXT Controller may be used to control a single *Robot* during the tournament. Each team will be required to "name" their NXT with their official FTC Team number expanded to four digits (e.g. FTC Team #123 would name their NXT "0123"). Should you come to the tournament with a spare NXT, then you should name that spare with your team number followed by a hyphen then a letter designation beginning with "B" (e.g. "0123-B", "0123-C").

Should a spare NXT be "loaned" to another team, the receiving team should rename the NXT with their corresponding team number along with the hyphenated letter designation showing the FCS that it is a spare.

<R9> Parts may NOT be modified as follows:

- a. Motors, sensors, controllers, battery packs, and any other electrical components may NOT be altered from their original state in ANY way.

Motor wires and power wires may be extended by splicing additional lengths of wire:

1. Motor wires are 22 AWG or larger
2. Battery wires are 16 AWG or larger

Welding, soldering (except as listed below), brazing, gluing, melting or attaching in any way that is not provided within the TETRIX System will NOT be allowed.

Soldering is allowed only:

1. As needed for electrical connections on the HiTechnic NXT Sensor Proto Board
2. As needed for splicing wires (all splices should be insulated with electrical tape or heat-shrink tubing)
3. As needed for 12V DC Motor connections. As needed for tinning ends of replacement power wires
4. Soldering may or may not be allowed in the pits at tournaments based on site-specific rules and requirements.

<R10> *Robots* must display their team number (numerals only, e.g. "106").

- a. The judges, referees, and announcers must be able to easily identify *Robots* by team number.
- b. Team number must be visible from at least two sides of the *Robot* (180 degrees apart).
- c. The numerals must each be at least three inches high, at least in 0.5" stroke width and in a contrasting color from their background.

<R11> The NXT controller must be accessible by competition personnel including inspectors, referees, and field control operators.

- a. The NXT battery must be easily removed with minimal disassembly of the *Robot*.

- b. The USB port on the NXT must be easily accessible to allow for rapid registration at the match.
- c. The NXT Controller LCD display must be readily visible.

<R12> *Robots* must include a mounting device to securely hold one FTC Robot Identification Flag throughout an entire match.

- a. The flags will be provided at the event
- b. The flag tube dimensions are 0.250" OD x 0.200" ID x 8.250" length with a triangular flag 4.000" high x 6.000" wide.

<R13> *Robot* TETRIX power switch must be mounted/positioned to be readily visible to competition personnel. The power switch must be installed according to the TETRIX system documentation (i.e. between the battery and the first HiTechnic DC Motor or Servo Controller)

<R14> Programming for *FIRST* Tech Challenges must be done with an approved programming language, using FTC Competition Templates. Approved programming languages are:

- a. NXT-G
- b. ROBOTC
- c. LabVIEW

Templates for all three programming choices are available at <http://www.ftctraining.com>

<R15> Energy used by *FIRST* Tech Challenge *Robots*, (i.e., stored at the start of a MATCH), shall come only from the following sources:

- a. Electrical energy derived from the onboard 12V battery, LEGO Power Function Battery Box, or the NXT batteries.
- b. Compressed air stored in the LEGO pneumatic system.
- c. A change in the position of the *Robot* center of gravity.
- d. Storage achieved by deformation of *Robot* parts. Teams must be very careful when incorporating surgical tubing or other items to store energy on their *Robot* by means of part or material deformation. A *Robot* may be rejected at inspection if, in the judgment of the inspector, such items are unsafe.

<R16> Game elements launched by *Robots* should not be launched with velocity greater than that required to reach a maximum of four (4) feet above the *Playing Field* surface, nor travel a horizontal distance greater than ten (10) feet.

<R17> Teams must provide their own computer for running the *Field Control System* software for each match. The FCS version should be latest version that is available from the FTC website before the tournament. Teams must demonstrate that their *Robot* switches between Autonomous mode and Tele-Op mode correctly using their version of the FCS.

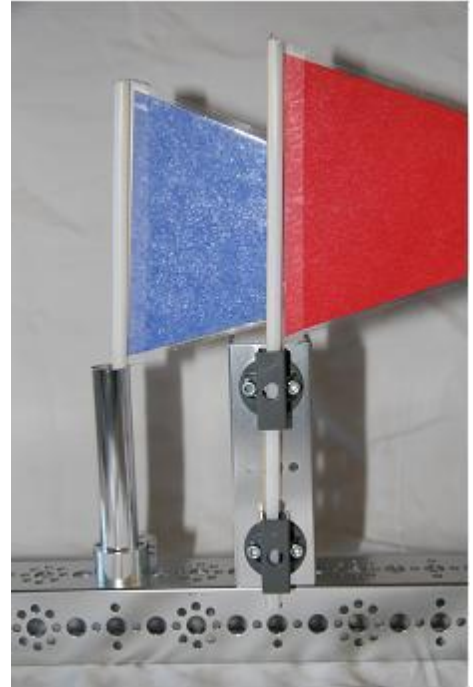

4.3 – PROGRAMMING GUIDELINES

Teams will have access to www.ftctraining.com as a resource to learn how to program with NXT-G, LabVIEW, or ROBOTC. The bulletin boards at the site will be managed daily by Robotics Academy staff. Information on the most current versions of the programming software can be found at www.usfirst.org/roboticsprograms/ftc/content.aspx?6650

NOTE TO TEAMS:**For NXT-G or LabVIEW:**

You **MUST** download the most current version (1.28) of the NXT device firmware to your NXT device in order to compete in the *FIRST* Tech Challenge (FTC) competition.

The field control system (FCS) at the FTC competition cannot communicate with your *Robot* unless you use the most current version of the firmware on the NXT device. The FTC software provides the correct version of this firmware.

Refer to the *FIRST* Tech Challenge Software Installation Instructions printed document, available as part of the FTC kit, for information about installing the FTC software.

Refer to Chapter 4, Controlling the *Robot* with the FTC Controller Station, of the Getting Started with the *FIRST* Tech Challenge Software manual for information about downloading the firmware from either LabVIEW or LEGO® MINDSTORMS® to the NXT device. Access the Getting Started with the *FIRST* Tech Challenge Software manual by navigating to the National Instruments\LabVIEW 8.5\manuals directory or the LEGO Software\LEGO MINDSTORMS Edu NXT directory and opening *FTC_Getting_Started.pdf*.

For ROBOTC:

The field management system at the FTC competition cannot communicate with your *Robot* unless you use ROBOTC firmware version 8.00 or higher on the NXT device. The 2.0 version of ROBOTC provides the correct version of this firmware.

Users of ROBOTC can refer to the instruction on the CD packaging for help on installing ROBOTC, or to the built-in help documentation in ROBOTC under "Help - Getting Started - Downloading Firmware (NXT)" for a step by step guide on how to download the latest firmware.

SECTION 5 – ENGINEERING NOTEBOOKS

5.1 – OVERVIEW

This section describes the requirements for creating the Engineering Notebook, including formatting guidelines, Judge’s tips, and the use of various forms of engineering support. It also provides sample pages from an award winning *FIRST* Tech Challenge Engineering Notebook.

5.2 – WHAT IS AN ENGINEERING NOTEBOOK?

One of the goals of *FIRST* and the *FIRST* Tech Challenge is to recognize the engineering design process and “the journey” that a team makes during the phases of the problem definition, concept design, system-level design, detailed design, test and verification, and production.

Throughout the building of your *Robot* you will come across some obstacles, lessons learned, and the need to draw things out on paper. This is where you and your team will use an engineering notebook. These notebooks will follow your team from kickoff throughout the competitions. Judges will review your Engineering Notebook to better understand your journey, design, and team.

Note: Refer to the judging criteria section of Section 7: Awards & Judging Criteria for more details on how your Engineering Notebook will be judged.

5.3 – THE NOTEBOOK

Electronic/Online: Teams may choose to use electronic or online programs to create their Engineering Notebook. For the purposes of judging, teams must print out their Engineering Notebooks and place them in a binder, no larger than 1”. All pages must be numbered and in order. Only one copy is required per team. Online videos or demonstrations cannot be considered this year.

Written: Laboratory or documentation notebooks are available through your school or local stationary supply store. There are many different types to choose from, using the following criteria:

1. Use a notebook with a stitched binding.
2. Do not use a loose leaf or spiral bound notebook.
3. Numbered pages are recommended (but not necessary) so that pages cannot be substituted or deleted.
4. Only one Engineering Notebook will be required per team.

5.4 – GUIDELINES/FORMAT

The *FIRST* Tech Challenge Engineering Notebook is a complete documentation of your team’s *Robot* design. This documentation should include sketches, discussions and team meetings, design evolution, processes, the “Aha’s!”, obstacles, and each team member’s thoughts throughout the journey for the entire season. A new notebook should be created for each new season. So here are the guidelines:

1. Document EVERYTHING!!
2. Engineering Notebooks should be organized enough to have an outsider understand your team and your journey.
3. Written entries should be in Permanent Ink – Not Pencil.
4. Start your notebook by introducing each team member and mentor with a brief biography of their name, age (or school year), interests, and reasons for joining your *FIRST* Tech Challenge team.

Tip: Pictures along with the bios would serve as a great visual for the judges to get to know each member of your team.

5. Start a fresh page at every meeting. Your team number, date, and start/stop times should be recorded when starting a new page. Each day should start with two columns:
6. Task Column – What your team is doing and discovering?
7. Reflections Column – Where your team records thoughts on what is happening and any questions that need to be answered.
8. Entries should be made by every team member, initialed, and dated.
9. All designs and changes to your *Robot* should be recorded directly into your notebook. The inclusion of all elaborate details and sketches are preferable. Notes and calculations should be done in your notebook, NOT on loose paper.

Tip: A judging panel is always interested to see a unique design or playing strategy. On the other hand, a design without the substance to support its reasoning will not be viewed as highly.

In the case of an error, draw a single line through the incorrect data. Do NOT erase or use correction fluid. All corrections should be initialed and dated.

Use both sides of a page. Never leave any white space: “X” out or Crosshatch all unused space, and don’t forget to initial and date.

To insert pictures or outside information into your notebook, tape the picture into your notebook and outline with permanent ink, to note that it was there in case it falls out. Put the corresponding page number on that inserted page.

Tip: Pictures or sketches of your *Robot* designs are recommended as part of a thorough documentation.

Insert your *Robot*’s Bill of Materials (BOM) as part of your Engineering Notebook as required by rules elsewhere in this manual.

The Engineering Notebook is also a good place to discuss and show team activities that are done throughout the team’s season. These activities can be placed in a separate section of the Engineering Notebook or chronologically within the design pages.

Don’t forget to put your team number in your Engineering Notebook and on your cover, so we know who to return it to after the judges have seen it!

5.5 – JUDGE’S TIPS

1. Every notebook is a work in progress, forever changing and developing. Judges do not want to see a “final” copy notebook; they want the real thing complete with misspellings, stains, worn edges and wrinkled pages. Just remember to keep it real!
2. When turning notebooks into the judges at your event, place sticky tabs at the top of the page on your top 6-12 best moments as a team. Judges will use these pages as their preliminary review of your notebook.
3. Don’t be afraid to customize your Engineering Notebook to reflect your team’s personality! At the end of the season, this notebook will be a great piece of memorabilia for your team.

5.6 – VIRTUAL HELP

It is in the spirit of *FIRST* to bring the technical knowledge of an engineer to high school students to broaden their awareness and knowledge of the engineering world. Please ask any questions you have about the Engineering Notebook in the Official FTC Q&A system.

5.7 – NOTEBOOK EXAMPLES

Scanned copies of award-winning Engineering Notebook examples are posted on the *FIRST* Tech Challenge website. It is strongly encouraged for teams to look over these as great examples of what the judges will be looking for when reading through your Engineering Notebooks.

SECTION 6 – FIELD CONTROL SYSTEM

6.1 – OVERVIEW

This section provides a general summary regarding the Field Control System (FCS) and how to use it for practicing with your *Robot* and for the competitions. Each team will be required to provide a computer at the event to run the FCS for their *Robot*.

The FCS is the software program that will be loaded on each team's computer for the purpose of running autonomous and *Driver* control modes both in competition and individually by teams to test their *Robots* and programming. This program is a very important part of the competition and members of the team need to understand how the program is used throughout the build season and during the events.

6.2 – THE FIELD CONTROL SYSTEM (FCS)

Matches at all tournaments will be run using the Field Control System (FCS) running directly on each team's own computer. Teams will bring to the *Playing Field* their own computer running the FCS, Logitech Dual Action game controllers, Bluetooth dongle and USB A-B cable. The main advantages for teams controlling their own *Robots* are improved cycle times between matches and the near elimination of match re-plays caused by a shared FCS.

Teams will establish the Bluetooth connection between their *Robot* and their FCS while waiting in the queuing area before the match. *Robots* will arrive at the *Playing Field* ready to start their match. Match cycle times will improve because the delay for all four *Robots* to connect, one at a time, to the shared FCS is eliminated.

Match re-plays will be significantly reduced because teams will have total control over their *Robot*, eliminating match re-plays caused by a failure of a shared FCS.

6.3 – FUNCTIONS PERFORMED BY THE FCS

The FCS will perform the following functions for teams in the *FIRST* Tech Challenge:

6.3.1 – ROBOT PAIRING AND FIELD CONNECTION

The FCS will allow the USB connection and will display the status of each of the connected Logitech Dual Action Gamepads. It will also perform the Bluetooth pairing process with the NXT and remember the connection to speed up the pairing process between matches. It will read the NXT to determine the name of the program that is to be used during the *Driver Controlled Period* of the match and display the name of that program on its display.

During match play, there will be controls in the FCS to disable the *Robot*, reconnect the Gamepads (should connection be lost), and reconnect to the NXT via Bluetooth (should connection be lost). There will also be a control to sever the Bluetooth connection to the NXT.

6.3.2 – ROBOT DEVELOPMENT CONTROL

The FCS is designed to be used by teams during their development process as well and to give them a feel of the program that they will use during the tournaments. There will be a place to input the name of the NXT being connected to confirm your connection and there will be indicators on the display to show the status of the connection between the computer and the NXT, the Gamepad controllers, and show whether the Autonomous program or the Operator Control program is running on the NXT. The FCS will insure that, the Gamepad controllers are disabled during Autonomous time.

6.3.3 – TEAM MATCH CONTROL

For matches, the FCS will provide input fields for the control of the time of Autonomous and *Driver-Controlled Periods* in minutes/seconds. There will also be check boxes to select whether there will be an Autonomous or Driver Controlled mode and whether to Pause between modes. There will be controls to Start, Stop, and Continue (after the optional Pause) the timer and Bluetooth messages to the NXT. There will be a digital timer display for seeing the competition match times. The FCS will also play the match sounds (Start of Match, Pause between modes, *End Game* indication, and End of Match) from your computer.

6.4 – HOW TO USE THE FCS

This section needs will be updated upon release of the 2009-10 version of the Field Control System software.

SECTION 7 – JUDGING & AWARDS CRITERIA

7.1 – OVERVIEW

This chapter provides a complete description of all of the *FIRST* Tech Challenge Awards; the judging process, criteria and philosophy that teams will need to be aware of in preparation for participating at a *FIRST* Tech Challenge Tournament.

In addition to winning points during the regional competition, the awards represent another positive way for mentors to instill important values like teamwork, creativity, innovation, and the value of the engineering design processes. These judging guidelines are a part of the road map to success.

7.2 – *FIRST* TECH CHALLENGE AWARDS ELIGIBILITY

To ensure fairness to all teams and to provide equal opportunity for all teams to win an award at a *FIRST* Tech Challenge Championship Tournament, teams are only eligible to win an award at the first three Championship Tournaments that they attend. Those teams who compete in more than three Championship Tournaments do so for the purpose of being involved in the fun and excitement of the tournament and not with the intention of winning multiple awards.

Teams have spent several weeks designing, building, programming their *Robot*, and learning what it takes to be a part of a team. For many FTC teams, the event is the reward for all their hard work throughout the season. While there are several types of events, they all offer a fun and exciting way for teams to demonstrate the result of their efforts.

7.2.1 - LOCAL EVENTS

Anyone can host a local event, also known as a scrimmage, to prepare for a Championship or Qualifier, or as an alternative to attending other events. If you choose to create and host a local event, you will be responsible for finding a location, organizing the format for the day, and inviting other teams to participate.

7.2.2 - QUALIFIERS

Hosted and managed by FTC Affiliate Partners or Partner-appointed hosts. Qualifiers, sometimes called Regionals, follow the same judging guidelines and format of Championship tournaments, but with a bit more flexibility. Qualifiers are usually held prior to Championship tournaments in regions where there are a plethora of FTC teams. The FTC Affiliate Partner will help determine the advancement criteria as to which teams move on to the Championship Tournament based on their performance at a Qualifier. The number of teams advancing to the state championship depends on the capacity of the state championship, the number of qualifying competitions and the number of teams attending the qualifying competition. Generally, the winner of the Inspire Award and the Winning Alliance will advance.

7.2.3 - CHAMPIONSHIP TOURNAMENTS

Hosted and managed by an FTC Affiliate Partner, Championship tournaments abide by certain standards in format, judging, awards, and overall quality. Some Championship tournaments require that teams win at a qualifying or regional tournament in order to advance to the Championship. Championships may include teams from a geographic region, province, state, country, or several countries. In past seasons, the winner of the Inspire Award and the Captain of the Winning Alliance at each Championship event received an automatic invitation to the FTC World Championship Event. Advance eligibility for the World Championship will be announced soon after this season's kickoff.

7.3 – *FIRST* TECH CHALLENGE AWARD CATEGORIES

7.3.1 – *FIRST* TECH CHALLENGE INSPIRE AWARD

This formally judged award is given to the team that truly embodied the 'challenge' of the FTC program. The team that receives this award is chosen by the judges as having best represented a 'role model' *FIRST* Tech Challenge Team. This team is a top contender for all other judging categories and is a strong competitor on the field. The Inspire Award Winner is an inspiration to other teams, acting with gracious professionalism both on and off the *Playing Field*. This team understands how to communicate their experiences and knowledge to other teams, sponsors, and the judges.

In past seasons, the winner of the Inspire Award at each Championship event received an automatic invitation to the FTC World Championship Event.

Guidelines for the Inspire Award

- Team must demonstrate respect and Gracious Professionalism both for team members and fellow teams
- Engineering Notebook must be submitted, and must impress the judges
- Team must work beyond their *Robot* to help spread awareness of the team within the community
- Team displays good communication and teamwork skills within the team as well as with their alliances
- Team communicates clearly about their *Robot* design to the judges
- Team presents themselves well in the judges interview
- Robot* effectively competes in the game challenge and impresses the judges
- Team and *Robot* consistently performs well during matches
- Team is a strong contender for all other judged awards

7.3.2 – ROCKWELL COLLINS INNOVATE AWARD

The Rockwell Collins Innovate Award celebrates a team that not only thinks outside the box, but also has the ingenuity and inventiveness to make their designs come to life. This judged award is given to the team that has the most innovative and creative *Robot* design solution to any or all specific field elements or components in the *FIRST* Tech Challenge game. Elements of this award include elegant design, robustness, and 'out of the box' thinking related to design. This award may address the design of the whole *Robot*, or of a sub-assembly attached to the *Robot*. The creative component must work consistently, but a *Robot* does not have to work all the time during matches to be considered for this

award. The team's Engineering Notebook should be marked with journal entries to show the design of the component(s) and the team's *Robot* in order to be eligible for this award, and entries should describe succinctly how the team arrived at that solution.

Guidelines for the Innovate Award

- Robot* or *Robot* sub-assembly must be elegant and unique in its design
- Creative component must work reliably
- Team must submit an Engineering Notebook
- Robot* is stable, robust and controllable
- Robot* design is efficient and consistent with team plan and strategy

7.3.3 – *FIRST* TECH CHALLENGE PTC DESIGN AWARD

This judged award recognizes design elements of the *Robot* that are both functional and aesthetic. All successful *Robots* have innovative design aspects; however, the PTC Design Award is presented to teams that incorporate industrial design elements into their solution. These design elements could simplify the *Robot's* appearance by giving it a clean look, be decorative in nature, or otherwise express the creativity of the team. The winning design should not compromise the practical operation of the *Robots* but compliment its purpose. This award is sponsored by Parametric Technology Corporation (PTC), developers of the CAD tools, Pro/ENGINEER and Mathcad. PTC gives licenses to the FTC student teams for these software products to help them with their designs.

Guidelines for the Design Award

- Team must submit an Engineering Notebook with detailed *Robot* design drawings
- Robot* differentiates itself from others
- Design is both aesthetic and functional
- Well thought out basis for the design (why i.e. inspiration, function, etc.)

7.3.4 – *FIRST* TECH CHALLENGE CONNECT AWARD

This judged award is given to the team that most connected with their local community and the engineering community. A true *FIRST* team is more than a sum of its parts, and recognizes that their schools and communities play an essential part to their success. The recipient of this award is recognized for helping the community understand *FIRST*, the *FIRST* Tech Challenge, and the team itself. The team that wins this award is aggressively seeking engineers and exploring the opportunities available in the world of engineering, science and technology. In addition, this team has a clear fundraising goal and plan to achieve that goal.

Guidelines for the Connect Award

- Team provides clear examples of outreach to community
- Team has worked to develop an in-person or a virtual connection with the engineering, science or technology community

Team has a business plan or other way of determining their fundraising needs and a plan to achieve their fundraising goal

Team has a plan to give back to their community

7.3.5 – *FIRST* TECH CHALLENGE MOTIVATE AWARD

This judged award celebrates the team that exemplifies the essence of the *FIRST* Tech Challenge competition through team spirit and enthusiasm. They show their spirit through costumes and fun outfits, a team cheer or outstanding spirit. This team has also made a collective effort to make *FIRST* known throughout their school and community.

Guidelines for the Motivate Award

Team spirit is consistent throughout the team and the competition.

Team is enthusiastic

The team functions well as a team

Team enthusiasm is evident in their community outreach

7.3.6 – *FIRST* TECH CHALLENGE THINK AWARD

This judged award is given to the team that best reflects the “journey” the team took as they experienced the engineering design process during the build season. The Engineering Notebook is the key reference for judges to help identify the most deserving team. The team’s Engineering Notebook should focus on the design and build stage of the team’s *Robot*. Journal entries of interest to judges for this award will include those describing the steps, brainstorming, designs, re-designs, successes, and those ‘interesting moments’ when things weren’t going as planned. A team will not be a candidate for this award if they have not completed the section of the Engineering Notebook describing the team’s experience.

Guidelines for the Think Award

Team must submit an Engineering Notebook

Engineering Notebook must demonstrate that the team has a clear understanding of the engineering design process, with pictures or drawings and details documenting all stages of *Robot* design

Engineering Notebook must be organized and follow the formatting guidelines provided by *FIRST* Collaboration and co-ownership are dominant themes in the Engineering Notebook or in the judges interview

Note: Teams should review Chapter 5: Engineering Notebooks for a complete description and format specifications.

7.3.7 – *FIRST* TECH CHALLENGE WINNING ALLIANCE AWARD

This award will be given to the winning alliance represented in the final match.

7.3.8 – *FIRST* TECH CHALLENGE FINALIST ALLIANCE AWARD

This award will be given to the finalist alliance represented in the final match.

7.4 – JUDGING PROCESS, SCHEDULE, AND TEAM PREPARATION

The schedules at the *FIRST* Tech Challenge tournaments may vary from site to site. Exact times for both the matches and meeting with judges cannot be given within this manual. All teams will either receive this schedule prior to or during check-in at the competition.

7.4.1 – JUDGING PROCESS

At the *FIRST* Tech Challenge Championship Tournament events, there will be three parts to the judging process: 1) interview with judges, 2) evaluation of performance, and 3) evaluation of the Engineering Notebook. Each team will have a “fact finding” discussion/interview with a panel of two or three judges. No awards will be determined on the basis of this interview alone. Judges will use the guidelines provided in this chapter to assess each team.

Teams should present their Engineering Notebooks at the Pit Administration Table during check-in but may be directed otherwise by the tournament officials. The Engineering Notebooks will be provided to the judges prior to the team interviews.

After the judges review the submitted Engineering Notebooks, complete the initial team interviews and evaluate the team and *Robot* performances during matches, they will convene to review their assessments and create a list of top candidates for the various judged awards. Judges may require additional impromptu discussions with teams if necessary. Deliberations are usually completed during the *Elimination Matches*. When the judges have finished their deliberations, the Engineering Notebooks will be returned to teams.

Teams are asked to bring their *Robot* to the judge interview. This is the best chance for teams to explain and demonstrate their *Robot* design to the judges in a quiet and relaxed environment.

7.4.2 – JUDGING SCHEDULE

The judging generally will take place in a separate area(s) away from the noise of the competition and pit. Teams will follow the schedule that outlines team interview times and locations. In some cases, teams may receive this information in advance, but more often, teams will receive this information when they check-in on the morning of the event.

Upon arrival please familiarize yourself with where the judging will occur and budget enough time to get there. To keep this process on time throughout the event, we require that all teams arrive at an adjacent queuing area five minutes before their scheduled interview.

7.4.3 – TEAM PREPARATION

Teams are encouraged to use the award guidelines to self assess where they are within an award category and help them establish higher goals. These guidelines will be the same ones used by the judges during each *FIRST* Tech Challenge event, and at the *FIRST* Tech Challenge World Championship.

Remember, this is the team's opportunity to highlight how they rallied as a team around the *Robot*; the technical knowledge they gained along the way; and how this experience has affected the members and mentors individually and as a team. Judges will want to hear from team member representatives and mentors. Since there are several awards with different criteria, teams may want to consider appointing different team members to speak with judges on the specific topics.

The mentors' contribution during the judging process will be kept to a minimum, however, the judges will like to know the highlights about the team; its history and make up; what the team achieved during the competition season; and the experiences that were gained. Team representatives' abilities to answer the questions or elaborate on *Robot* design functions or attributes with minimum direct assistance from the mentors will be evaluated during the team interview.

7.5 – *FIRST* TECH CHALLENGE CHAMPIONSHIP EVENT ELIGIBILITY

The culmination of the *FIRST* event season is the *FIRST* World Championship Event held at the Georgia Dome in Atlanta, GA. This event represents the conclusion of the season for *FIRST* LEGO League (FLL), the *FIRST* Tech Challenge (FTC), and the *FIRST* Robotics Competition (FRC). This is a fun and exciting experience for teams in all programs to participate.

For this season, *FIRST* Tech Challenge teams will need to earn their way to the *FIRST* World Championship. Eligibility is earned by your performance on and off the field. The criteria for eligibility to the event will be announced later in the season. Teams will still be responsible for their own entry fees, lodging, and travel costs to the *FIRST* World Championship.

SECTION 8 – TEAM RESOURCES

8.1 – OVERVIEW

This chapter provides teams with necessary information for contacting *FIRST* Tech Challenge staff, accessing technical support, using the FTC Q&A system, and using the *FIRST* and *FIRST* Tech Challenge logos.

8.2 – *FIRST* CONTACT INFORMATION

You can reach the *FIRST* Tech Challenge staff by phone at (603) 666-3906 or e-mail at FTCteams@usfirst.org. The office is open Monday through Friday from 9:00 a.m. to 5:00 p.m., EST. Be sure to provide your team number in your message and leave contact information. Refer to the information below for the appropriate resource.

8.3 – GETTING ANSWERS TO YOUR QUESTIONS

For general information and questions regarding the *FIRST* Tech Challenge, please send an e-mail request to FTCteams@usfirst.org.

For questions regarding the *FIRST* Tech Challenge *Hot Shot!* game, please have your team leader log into the TIMS (Team Information Management System) to see your FTC team forum login under the ‘What’s New’ information once your team has registered and paid with the *FIRST* Tech Challenge.

** Please note that accounts are updated weekly by our IT Department. If you have trouble accessing the forums, please feel free to contact *FIRST* at the information above.**

The free forum account needs to be registered and activated in order to ask official game questions. The FTC Interactive Manual and Game Q&A is accessed directly at <http://forums.usfirst.org/forumdisplay.php?f=26> or by browsing to forums.usfirst.org and following the “*FIRST* Tech Challenge” link found under the “*FIRST* Programs” heading. Please do not use the FRC Game Q&A for FTC Questions.

For detailed information on the *FIRST* Tech Challenge program, robot kit and accessories, *Playing Field*, etc., visit the following websites:

Website	Description
www.usfirst.org/roboticsprorams/ftc/default.aspx	FTC information, FAQs, and team resources
http://forums.usfirst.org/forumdisplay.php?f=26	FTC Game Q&A
www.ftctraining.com	NXT-G, LabVIEW and ROBOTC tutorials

8.4 – TECHNICAL SUPPORT

It is in the spirit of *FIRST* to bring the technical knowledge of an engineer to high school students to broaden their awareness and knowledge of the engineering world. There are many online resources to find help with the TETRIX™ Robotics Design System as well as many examples of the versatility of the kit. Should you have questions or need technical help or information about TETRIX or the software, please refer to www.ftctraining.com.

8.5 – TEAM DEVELOPMENT SUPPORT

In addition to the staff at *FIRST* Headquarters, an additional regional level of support is available through the *FIRST* Tech Challenge Affiliate Partners, *FIRST* Regional Directors, *FIRST* Senior Mentors, and VISTA Volunteers. The FTC Affiliate Partners coordinate all FTC activities within a state, province, or region, and should be your foremost resource for help with the program. To find an Affiliate Partner, Regional Director, Senior Mentor, or VISTA volunteer available in your area, please contact *FIRST* at FTCteams@usfirst.org.

8.6 – USING THE *FIRST*, FTC, AND GAME LOGOS

We encourage teams to develop and promote team identity. It is a great way to help *FIRST* judges, announcers, and audiences recognize your team at the competition, and it is also a way to help you create a “buzz” about your team in your community.

You have incredibly creative opportunities in terms of designing your own identity. There are many examples of how teams “brand” their efforts with websites, incredible team logos on *Robots*, t-shirts, hats, banners, fliers, and giveaways.

You can download the *FIRST* and FTC logos and Logo Standards information from the *FIRST* Tech Challenge web site at <http://www.usfirst.org/roboticsprograms/resourcecenter.aspx?id=746>. Keep in mind the following when working with the *FIRST* and FTC logos:

Positive Promotion: Use the *FIRST* and FTC logos in a manner that is positive and promotes *FIRST*.

Unmodified: Use the *FIRST* and FTC logos without modification. This means that you will use our name and the circle, square, and triangle as you see it on our website or letterhead. You can use it in red, blue, and white, or in black and white.

Modification Permission: If you have an interest in modifying the *FIRST* and FTC logos, you must first contact *FIRST*. Please submit a written request letting us know why you want to modify the logo, how you plan to do it, and where you plan to apply it. Send an e-mail request to the *FIRST* Marketing Department, marketing@usfirst.org.

Advertising Use Approval: All teams and sponsors must obtain approval from *FIRST* prior to incorporating our logo in any advertising. Send an e-mail request for advertising approval to marketing@usfirst.org.

SECTION 9 – ROBOT INSPECTION

9.1 – OVERVIEW

This section describes *Robot* Inspection for the FIRST Tech Challenge 2009-2010 competition, *Hot Shot!* It also lists the inspection definitions and inspection rules.

9.2 – DESCRIPTION

The FTC *Robot* will be required to pass hardware and software inspections before being cleared to compete. These inspections will ensure that all FTC *Robot* rules and regulations are met. Initial inspections will take place during team registration/practice time. A copy of the official FTC “Robot Inspection Sheet” is located in this section. The “Robot Inspection Sheet” should be used by the teams as a guide to pre-inspect the *Robot* prior to arriving at the event.

9.3 – DEFINITIONS

Robot – An operator controlled and/or autonomous programmed vehicle designed and built by a FIRST Tech Challenge team to perform specific tasks while competing in this year’s competition. The *Robot* may only be constructed from materials and components outlined in Section 4.2.

Robot Initialization Routine – A set of programming instructions inserted immediately prior to the match control loop of the Autonomous Mode program that serves to ready the *Robot* for a match.

Robot Sizing Box – A sturdily constructed cube with the interior dimensions; 18 inch (45.72cm) by 18 inch (45.72cm) by 18 inch (45.72cm) that has one open side with an interior opening size of 18 inch (45.72cm) by 18 inch (45.72cm). The Sizing Box is used for *Robot* Inspection as outlined in Section 9.4.

9.4 – INSPECTION RULES

<I1> FTC teams must submit their *Robot* for inspection prior to participating in practice rounds. At the discretion of the FTC Lead Inspector, the *Robot* may be allowed to participate in practice rounds before passing inspection.

<I2> The team’s *Robot* must pass all inspections before being allowed to compete in Qualification Rounds. Noncompliance with any *Robot* design, construction rule, or programming requirements may result in disqualification of the *Robot* at a FTC event.

<I3> The FTC Official Team Number must be displayed on the *Robot* prior to inspection as defined in Section 4.2 <R10>.

<I4> *Robot* construction is constrained by the number of Official FTC Competition components a team may use as defined in Section 4.2<R5>. There is not a specified FTC *Robot* weight constraint.

<15> The maximum size of the *Robot* for starting a Qualifying or *Elimination Match* is 18 inches (45.72cm) wide by 18 inches (45.72cm) long by 18 inches (45.72cm) high. The *Robot Sizing Box* will be used as the official gauge in determining conformance to this rule as follows:

The *Robot* must be self-supporting while in the *Robot Sizing Box* either:

- a. by mechanical means with the *Robot* in a power-OFF condition
- b. by a *Robot Initialization Routine* in the Autonomous mode program that may pre-position the servo motors, with the *Robot* in a power-ON condition, to the desired position by means of a single instruction to the Hitechnic Servo controller for each servo motor effected. If the *Robot Initialization Routine* does move the servos prior to the official start of the match, there must be an indicator on the *Robot* of this fact. A warning label such as the following will suffice:



<16> All *Robots* placed on the field will maintain the size constraints outlined in <105> until the beginning of match play.

<17> When an FTC team makes a modification to improve performance or reliability of their *Robot*, the team may request a re-inspection of their *Robot* by an FTC Inspector.

<18> It is the FTC Inspectors responsibility to evaluate *Robots* to insure each *Robot* has been designed to operate and function safely. Section 2.4.3 <S1> and Section 4 specify the safety rules and limitations that apply to the design and construction of all *Robots*.

<19> *Robot* inspection is a Pass / Fail process. A *Robot* has passed inspection when ALL requirements listed on the official FTC "Robot Inspection Sheet" have been successfully met and recorded as passed by an FTC Inspector.

COMPETITION INSPECTION CHECKLIST

Team Number: _____

Time of Inspection: _____

Pass/Fail: _____

Inspection Type: ___ Initial ___ Mandated ___ Random

	Size Inspection	
	Robot fits within the Sizing Box (18" x 18" x 18") without exerting force on box sides or top	R4a
	Beginning at 10" above the tile surface, Robot may not extend more than 10" horizontally.	R4b
	Overall Inspection	
	Team Number is visible from 2 sides, is written in 3" tall, 1/2" stroke on a contrasting background	R10
	Robot does NOT contain any components which will be intentionally detached on the playing field	R3/G7
	Robot does NOT contain any components that could damage the playing field or other robots	R3
	Robot does NOT contain any sharp edges or corners	R3
	Robot poses NO obvious unnecessary risk of entanglement	R3
	NXT battery can be easily removed without disassembly	R11a
	USB port is easily accessible for rapid registration	R11b
	NXT Controller LCD display is readily visible	R11c
	Robot Flag Holder is present and adequately holds the flag during normal robot operation	R12
	TETRIX Power Switch is positioned to be readily visible to competition personnel and installed properly	R13
	ALL Decorating Components on the Robot NOT meeting FTC Inspection Criteria are NON FUNCTIONAL	R5f
	Game elements launched by Robots do not reach a maximum of four (4) feet above the field surface, nor travel a horizontal distance greater than ten (10) feet	R16
	Parts Inspection - Official TETRIX and LEGO Components	
	ALL Robot components are OFFICIAL TETRIX or LEGO Products	R5
	FTC Robot does not utilize any of the Packaging materials	R5c
	Robot has only (1) NXT controller	R5b
	Robot uses maximum of three (3) NXT Motors	R5b
	Robot uses maximum of eight (8) 12V DC drive motors	R5a
	Robot uses a maximum of twelve (12) servos (Hi Tec, HS-475HB)	R5a
	Robot uses a maximum of four (4) HiTechnic DC Motor or Servo Controllers (in any combination)	R5a
	Robot uses one (1) official NXT rechargeable battery pack or six (6) AA batteries (not both)	R5b
	Robot uses one (1) official FTC 12 V DC NiMH battery	R5a
	Additional Parts Inspection	
	Robot contains no more than 24"x24"x0.10" thick polycarbonate	R5c
	Robot contains no more than 24"x24"x0.0625" thick aluminum	R5c
	Robot contains no more than 24"x24"x0.040" thick Kydex	R5c
	Robot contains no more than 24"x24"x0.0625" thick ABS plastic	R5c

2009-10 *FIRST*® TECH CHALLENGE GAME MANUAL

	Robot contains no more than 24"x24" of Non-Slip Pad	R5c
	Robot contains rope or cord not thicker than 0.125" diameter	R5c
	Robot contains plastic coated wire rope not thicker than 0.03125" diameter	R5c
	Robot contains no more than 36" length of PVC piping not thicker than 3" inside diameter	R5c
	Robot contains any number of rubber bands not larger than #32 (0.125" thick & 3" in circumference)	R5c
	Robot contains no more than 24" length of surgical tubing 0.25" outside diameter or smaller	R5c
	Robot contains electrical tape or heat shrink tubing only if used as electrical insulation	R5c
	Robot contains any number of cable ties not to exceed 8" in length	R5c
	LEDs (if used) must be visible light and only used as a signaling device or for decoration	R5c
	Robot contains no more than 24"x24"x 0.080" thick PETG	R5c
	Construction Inspection	
	NO electrical components have been modified from their original state except the HiTechnic Prototype Board	R9
	NO method of attachment NOT provided by the Tetrix except as specified as allowable per rule R5 and R9 (i.e. PVC cement on PVC, etc.)	R5/R9
	If thread locker is used, it is used for securing screws & fasteners ONLY	R5c
	Software Functionality Check	
	Robot has passed Software Inspection	R14
	Robot has the correct name based on the team's FTC number	R8
	If Robot uses an Initialization Routine to move servos prior to start of match, a warning sticker is in plain sight on the robot.	I5
	Team is using the latest published version of the Field Control System (FCS) on their own computer	R17
	Team has demonstrated that they are using the correct version of the programming template	R14

Reason for Failure (if any):

I hereby state that all of the above is true, and to the best of my knowledge all rules and regulations of the 2009-2010 *FIRST* Tech Challenge have been abided by.

Inspector

Team Student Representative